

# AMCL2

# USER'S MANUAL



# peecker sound®

SOUND REINFORCEMENT

CONTROLLED RADIATION

ACOUSTIC RESEARCH

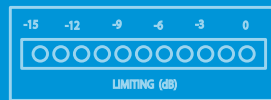

## TABLE OF CONTENTS

|  |                |
|--|----------------|
| <b>TABLE OF CONTENTS</b>                                 |                |
| <b>1. IMPORTANT SAFETY INSTRUCTIONS</b>                  | pag. <b>3</b>  |
| <b>2. DECLARATION OF CONFORMITY</b>                      | pag. <b>3</b>  |
| <b>3. WARRANTY</b>                                       | pag. <b>3</b>  |
| <b>4. USER LIABILITY</b>                                 | pag. <b>4</b>  |
| 4.1 Dangerous output voltage                             |                |
| 4.2 Radio interferences                                  |                |
| <b>5. INTRODUCTION</b>                                   | pag. <b>4</b>  |
| 5.1 Unpacking  |                |
| 5.2 Installation   |                |
| 5.3 Front panel  |                |
| 5.4 Rear panel   |                |
| <b>6. CONNECTIONS</b>                                    | pag. <b>6</b>  |
| 6.1 Connection cables                                    |                |
| 6.2 Power supply   |                |
| <b>7. FEATURE DESCRIPTION</b>                            | pag. <b>6</b>  |
| 7.1 Advantages of multi-band limiters over wideband ones |                |
| 7.2 Automatic threshold corrector                        |                |
| 7.3 Functional features                                  |                |
| 7.4 Controls and functions                               |                |
| <b>8. SETUP</b>  | pag. <b>8</b>  |
| 8.1 XLR connections                                      |                |
| <b>9. SAMPLE CONFIGURATION</b>                           | pag. <b>9</b>  |
| <b>10. TECHNICAL SPECIFICATIONS</b>                      | pag. <b>10</b> |

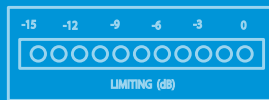
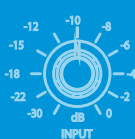

## 1. IMPORTANT SAFETY INSTRUCTIONS



This symbol indicates *key operating instructions and information* requiring particular attention for correct use of the product.



This symbol warns of *dangerous voltage* and the consequent risk of electric shock. Take extra care and proceed with caution.

1. Read carefully all the attached product documentation and keep for further reference.
2. Heed the warnings.
3. Keep the packaging and check that all the material is in perfect condition.
4. Do not use the product in the vicinity of water or pour water or any other liquid on the processor. Take care not to use it with wet hands or with your feet in water.
5. Do not use near sources of heat such as radiators, stoves or other heat-producing appliances.
6. Check that the power cable is intact and undamaged. Do not tread on the cable and take care not to put any pressure on the plug.
7. Connect the plug to a properly earthed electric socket. Do not tamper with the plug. Should the plug supplied not fit your socket, have an electrician replace it with the correct one.
8. Connect to the mains supply having identical voltage as that indicated on the back of the processor.
9. Install the processor in compliance with the instructions.
10. Disconnect the appliance in case of storms or when not in use.
11. Wire exclusively as shown in the instructions.
12. Do not remove the upper or lower covers as this would expose the user to the risk of electric shock.



13. Do not attempt to repair the appliance yourself but always seek the assistance of qualified technicians.
14. Clean with a dry cloth only.
15. The product must be handled by qualified technicians when:
  - the power cable or the plug is damaged
  - the product has been exposed to rain or humidity
  - liquid has got inside the unit
  - an object has fallen on the unit
  - the unit has fallen and is damaged
  - the appliance seems to be malfunctioning or is showing a marked change in performance
16. Careful supervision is required if the product is used in the presence of children or by unskilled adults.

## 2. DECLARATION OF CONFORMITY

This device complies with the requirements of the *European Electromagnetic Compatibility Directive 89/336/EEC* (and relevant 92/31/EEC amendment), as well as the requirements of the *Low Voltage Directive 72/23/EEC* (and relevant 93/68/EE amendment).

Regulations applied:  
EN 55 103-1 (*Emissions*)  
EN 55 103-2 (*Immunity*)  
EN 60065 Class I (*Safety*)

## 3. WARRANTY

**Peecker Sound** products are guaranteed against malfunction due to defective materials or workmanship for a specified period of time, starting from the date of original purchase. Should a malfunction occur during the warranty period, the product will be repaired or replaced (at the manufacturer's discretion) free of charge. The shipping costs and related risks, and any loss during shipment to authorized service centres are the responsibility of the customer. The product will be returned to the customer with a carriage forward shipment.

### Warranty terms

The warranty covers the appliance under its initial purchase in compliance with the laws in force. The warranty is valid for *3 years*, starting from the date of receipt of the product. Peecker Sound reserves the right, in certain cases, to decide to replace the appliance with another identical or similar product. The warranty is not extended following a product failure. The warranty does not cover any incidental or consequential damages, without limitation, caused to persons or property during any period of inefficiency of the appliance.

### Exclusions and limitations

The warranty does not apply to:

- any damage to exterior finishings or surfaces, aesthetic elements, or electric/electronic parts resulting from negligent use of the product;
- malfunction resulting from incorrect or improper use of the product or from transport without due care;
- malfunction resulting from repairs carried out by unauthorized persons or service centres;
- malfunction due to circumstances that cannot be ascribed to manufacturing defects of the appliance;
- plastic or glass parts, bulbs and the like, as well as all that can be regarded as normal wear and tear. As regards circuit components (transistors, diodes, etc.) the general terms set by the original manufacturers apply.

The following are also not covered by the warranty:

- damage caused by accidents, product modifications, negligence or incorrect connection
- damage that occurred during transport
- damage resulting from failure to comply with the instructions contained in the user's manual
- claims based on misrepresentations by the seller and any product whose serial number has been rubbed off, modified or removed.

### Receiving warranty service

To receive repair or replacement of the product under warranty, the customer must deliver the product in its original packaging carriage paid to an authorized Peecker Sound service centre together with the relevant proof of purchase, i.e. bill of sale, receipt or invoice.

The warranty service and list of authorized service centres is available at the address below:

#### **Peecker Sound - "After Sales Service"**

Via Monti Urali, 29 - 42100 Reggio Emilia (Italy)  
Tel: +39 0522 557735 - Fax: +39 0522 391268  
E-mail: [info@peeckersound.com](mailto:info@peeckersound.com)

Repair or replacement of the product and its return to the customer are the only services provided to the customer. Peecker Sound shall not be held liable to pay incidental or consequential damages including, without limitation, injury to persons or property or loss of use.

### Costs paid by Peecker Sound

Peecker Sound will pay for all labour and material expenses necessary for the repairs covered by the warranty. Make sure you keep the original packaging; otherwise, the cost of replacing will be charged to you if necessary. Produce the original invoice to establish the date of purchase.

Do not send the product to the factory without prior authorization. Should shipment of the product be a problem, please contact the service centre, who will deal with it promptly. Otherwise, the customer is responsible for shipment and handling of the product to be repaired and payment of all shipping costs.

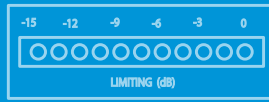

## Limitation of implicit warranties

All implicit warranties, including guarantee of merchantability and suitability to specific purposes, are limited to the duration of the present warranty. With the exception of certain types of damage, Peecker Sound liability is limited to repairing or replacing, at its discretion, any defective products, with no obligation of compensation for any kind of incidental or consequential damages. In case of any controversy, the court of jurisdiction will be exclusively the Court of Reggio Emilia (RE) – Italy.

## 4. USER LIABILITY

### 4.1 Dangerous output voltage



Do not touch exposed speaker cables while the processor is operating.

### 4.2 Radio interferences

A sample of this product has been tested and approved in compliance with the limits set out by the *Electromagnetic Compatibility Directive* (EMC). These limits have been determined in order to provide reasonable protection from dangerous interferences caused by electrical appliances. Should this product not be installed or used in compliance with the instructions as set out in this manual, it might interfere with other appliances such as radio receivers, for example.

There is no guarantee, however, that interferences will not occur in a particular installation.



Should the device interfere with two-way radios (switching the device on and off will allow you to check whether this is the case), you should try to eliminate the interference by adopting one of the following measures:

- Increase the distance between the appliance and the receiver.
- Connect the appliance to a socket positioned on a circuit different from the one the receiver is connected to.
- Re-position or move the aerial of the receiver.

Check that the unit complies with the EMC immunity limits (it must carry the CE mark). All electrical appliances sold in the EU must be approved for immunity to electromagnetic fields, high voltage and radio interferences. Seek professional assistance.

## 5. INTRODUCTION

Congratulations on your choice of Peecker Sound **Automatic Multiband Controller & Limiter (AMCL2)** and thank you for your confidence in us and our products.

Your controller/limiter has been carefully engineered down to the smallest detail, from component selection to final assembly.

All Peecker Sound products aim for full customer satisfaction and you can rest assured that the product you have chosen uses cutting-edge technology.

The AMCL2 has been designed in the Sound Corporation Design and Research & Development (R&D) departments paying particular attention to the choice of materials, safety devices and electronic design for the manufacture of a safe, reliable and long-lasting product.

Since inappropriate use of the device can jeopardize its correct operating performance, please ensure that you use it carefully and correctly.

Please read this manual carefully: all the information it contains is vitally important for using your appliance safely.

## 5.1 Unpacking

Inspect the packaging and its contents immediately to check whether there are any signs of damage. After unpacking, inspect the product and any accessories. Should you notice any damage, inform your dealer immediately.

Please keep all the packaging materials, which will be useful for returning the product to Peecker Sound or sending it to one of our authorized *Service Centres* if the product does not arrive in perfect condition. Use exclusively the original packaging, as it is the best way to protect the appliance from mishandling by the carrier.



Please take care of the environment. Once the device has become obsolete, please dispose of it in the appropriate recycling container.

## 5.2 Installation

The Peecker Sound Automatic Multiband Controller & Limiter (AMCL2) has been designed to stand on a surface (e.g. a table) or to be installed in a rack unit (1 RU) for standard 19" rack mounting.

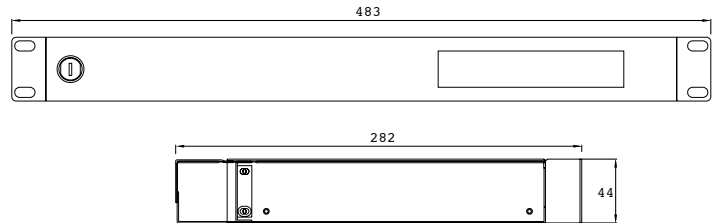

Figure 1. AMCL2 unit dimensions

Remember to allow an extra clearing space of 10cm at the back for the connectors.

Do not set the unit directly on top of power amplifiers or power supply units, as the heat and electromagnetic fields produced by these appliances can interfere with correct device operation.



When moving the equipment with a trolley take extra care not to injure yourself.

Please remember that the unit should not be installed in venues with:

- High temperatures;
- Dust or excessive humidity;
- Intense magnetic fields;
- Water in the vicinity of the unit;
- Vibrations;
- Enclosed spaces that inhibit proper ventilation.

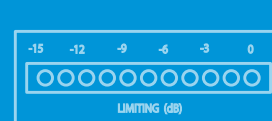
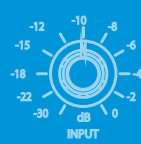

## 5.3 Front panel

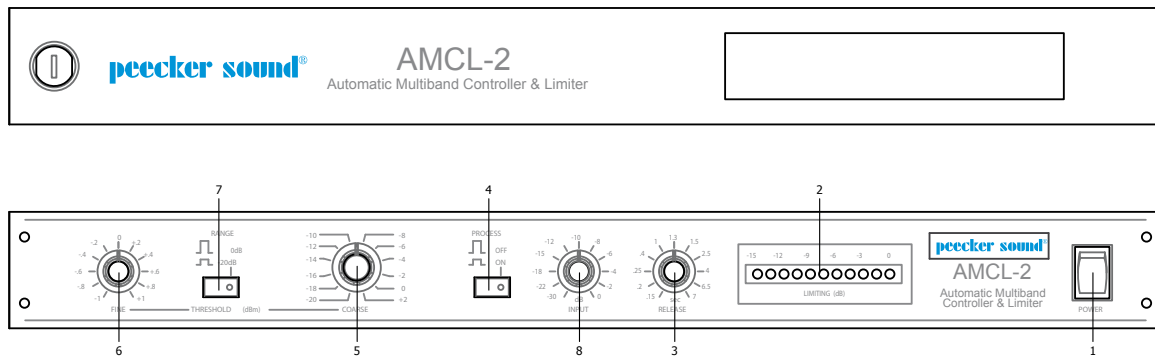

Figure 2. AMCL2 Front panel and cover

1. **Power** - Power switch.
2. **Limiting** - LED meter indicator (in dB) of the limiter intervention.
3. **Release** - This potentiometer adjusts the release time.
4. **Process** - This button enables by-pass of the device.
5. **Coarse** - Potentiometer that adjusts the threshold level from -20 dB to +2 dB.
6. **Fine** - Potentiometer that adjusts the threshold level with a more accurate range (from -1 to +1 dB).
7. **Range** - Button to select the most appropriate activation threshold by selecting an attenuation of 20 dB.
8. **Input** - Potentiometer of the input level control.

## 5.4 Rear Panel

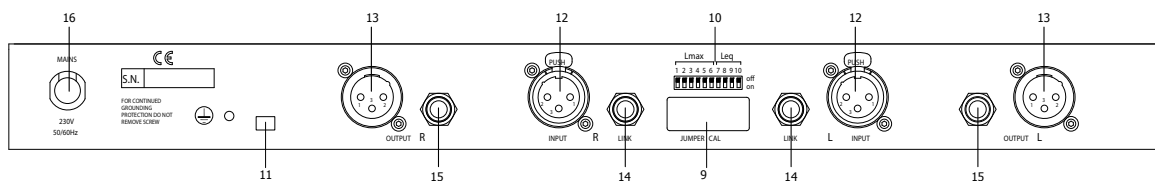

Figure 3. AMCL2 Rear panel

9. **Jumper cal** (only with OPTIONAL board) - It allows the input signal to drive the intervention of the optional board.
10. **Lmax, Leq** (only with OPTIONAL board) - Dipswitch selector to change Leq and Lmax parameters.
11. **Ground Lift** - Earth change to connect-disconnect electrical earth to/from mechanical earth.
12. **Input** - Female Neutrik® XLR input connectors.
13. **Output** - Male Neutrik® XLR output connectors.
14. **Link** - 6.3 mm Jack input and output connectors for input signal loop through.
15. **Output** - 6.3 mm Jack output connectors.
16. **Mains** - Power supply cable with CEE 7/7 Schuko plug



## 6. CONNECTIONS



Check that your mains power voltage corresponds to that indicated on the back of the unit.  
 Before connecting the cable to the AC mains make sure it is undamaged and that there are no bare cables.

Remember to turn off the limiter before connecting it to or disconnecting it from any other units.

### 6.1 Connection cables

Input and output wiring diagrams are shown in Figure 4. *Neutrik® XLR* connectors are used for connecting the main audio inputs and outputs, while 6.3 mm *stereo Jacks* are used for auxiliary connections. To guarantee the maximum performance, both inputs and outputs are balanced without the use of transformers. In any case, the cross-coupled output stage allows for both balanced and unbalanced connection without noticeable differences in level. In the case of unbalanced connection, the unused pin (2 or 3) must be short-circuited with pin 1 (GROUND), and in this case, the 70 Ω impedance of the outputs allows you to drive even long capacitive lines without any problems. Finally, the jumper on the rear panel allows you to select NORMAL or CAL operation when tuning the system.

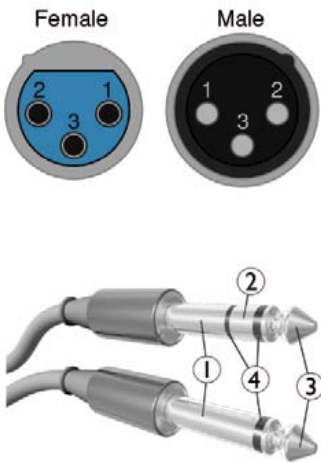

Figure 4. Cannon® XLR and Jack connectors

### 6.2 Power supply

The appliance is designed to operate with a 230 VAC – 50/60Hz mains power supply.  
 Should the unit fail to work when switched on, check the protection fuse; if it blows immediately, do not try to resolve the matter yourself but have the appliance checked by a qualified service centre.

## 7. FEATURE DESCRIPTION

The Peecker Sound Automatic Multiband Controller & Limiter (AMCL2) is a multiband device expressly designed to control the sound pressure level (SPL) within a space. It belongs to the category of devices commonly called **dynamic processors** capable of acting on the audio signal level or width in a variable way, depending on the spectral distribution of the audio signal itself. Dynamic processors are designed to optimize the signal based on the features of the transmitting device being used or the type of appliances adopted for the sound reproduction system.

When talking about the *dynamic range* of a music program, we mean the *difference*, normally expressed in dB, between the *maximum* (undistorted) *level reached by the signal and its minimum “useful” level*, i.e. capable of being perceived by the human ear. The maximum output signal of an appliance is normally limited by the adjustment of the power supply side, since the excursion can never exceed the supply voltage. Minimum output level, on the other hand, is determined by the background noise level, since a signal whose level is below that of background noise cannot actually be picked up. Modern professional equipment can produce a dynamic range capable of reaching up to as much as 120 dB.

Multi-band limiters are used to reduce the dynamics of the input signals being received. This reduction is determined by the fact that a highly dynamic signal is difficult for a sound reinforcement system to handle, which is indeed the reason why existing regulations impose limits on audio signal levels.

Typically, such devices are used for amplification systems in public venues where sound pressure equivalent level (Leq) and maximum level (Lmax) cannot exceed the limits required by the applicable national rules and regulations. Using a suitably configured AMCL2 unit allows the system to comply with such restrictions even if the source signal has been unintentionally adjusted to exceed them.

Unlike traditional systems, the AMCL2 guarantees the highest quality result, where the sound is free from modulations or unpleasant “pumping” effects that may lead to volume fluctuations. Thanks to the possibility to manage different frequency bands (*Low, Mid and High*), the musical message is optimized for the entire frequency range, producing rich and modulated bass notes and crystal clear high notes.

### 7.1 Advantages of multi-band limiters over wideband ones

The use of multi-band limiters has become necessary in the world of professional audio to make up for the shortcomings of wideband limiters, which suffer from the problem of spectral intermodulation distortion where, in practice, the linear combination of incoming signals causes a spectral alteration of the overall gain, thereby producing intermodulation effects. Typical examples of this problem include situations in which the voice signal drops as a result of a drum roll, for example, or when an extra, unplanned speaker is introduced, causing a reduction in the overall spectral content.

Low frequencies – which have a higher energy content – normally tend to control the entire spectral content; when the lowest frequencies exceed a set threshold limit, the high frequencies are attenuated and consequently the sound output becomes dull and restrained.

Unlike wideband limiters, multiband limiters do not behave this way but actually produce a spectral separation of the audio signal into multiple frequency bands so that they can be processed separately.

This can lead to more serious design and implementation problems, but these can be resolved by using an “intelligent circuit” capable of controlling all the parameters automatically, thereby keeping to a minimum the set of controls.

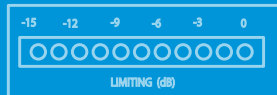
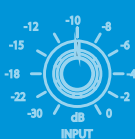

## 7.2 Automatic threshold corrector

The multi-band limiter divides the audio signal into different, individually limited frequency bands and then adds them together. The resulting level can sometimes be different from the set threshold. With conventional methods using wideband limiters, the problem of intermodulation distortion mentioned earlier would arise.

When using the AMCL2, by contrast, the sum of the two bands is sent to an automatic correction circuit. If this exceeds the benchmark value, the circuit automatically adjusts the individual thresholds of each band. When the value falls below the benchmark level, the individual thresholds of each band return to their original value. This way, the sound maintains the utmost sharpness and is free of noticeable distortions.

Finally, the AMCL2 uses a single automatic correction circuit for both channels, providing perfect balancing of the stereo image with equal limitation on both channels.

## 7.3 Functional features

A key feature of the Automatic Multiband Controller & Limiter (AMCL2) is that it is a *unitary gain* device, i.e. an input signal variation is matched by an identical output signal variation. To enable the device to operate correctly, the front panel is fitted with the following four different controls: input level, time release and two threshold controls.

In addition, the simple design of the front panel with just a few controls makes the AMCL2 easy to install and test. It comes complete with a lockable front cover, as prescribed by existing regulations, to prevent possible tampering by unauthorized users.

## 7.4 Controls and functions

### • Release time

*Release time* enables the density of the music program to be altered. It can be defined as the *interval between the time when the limiter acts to restore the signal level and the time when the signal being processed returns below threshold*. Differences in the duration of this parameter cause changes in spectral characteristics.

An extremely short release time gives a very narrow dynamic range that can cause distortion at low frequencies. By selecting a fairly short release time, the output will be kept as close as possible to the maximum level.

Conversely, as release time is increased, distortion will be reduced, resulting in a softer, more rounded sound.

Finally, setting an extremely long time release will lower the average output value, particularly if the music program contains considerable and fast variations in level (transients).



Figure 5. Time Release selector

### • Threshold level control

There are *three* controls to adjust the threshold level on the front panel of the AMCL2. The first control (5 in Fig. 2), labelled COARSE, is an electronic switch adjustable in 2 dB steps ranging from -20 dBm to +2 dBm. The second control (6 in Fig. 2), labelled FINE, is much more precise and allows for correction of the preceding setting with a range of action from -1 dBm to +1 dBm. If the level of the music program to be controlled is too high and the COARSE selector is insufficient, a third control labelled RANGE (7 in Fig. 2) can be used to reduce the output level by 20 dB. Using these three controls simultaneously allows you to adjust the total threshold level in a 44 dB interval.



Figure 6. Threshold selector

Note that the limiter can be regarded as a special compressor, representing a compression ratio of  $\infty:1$ .

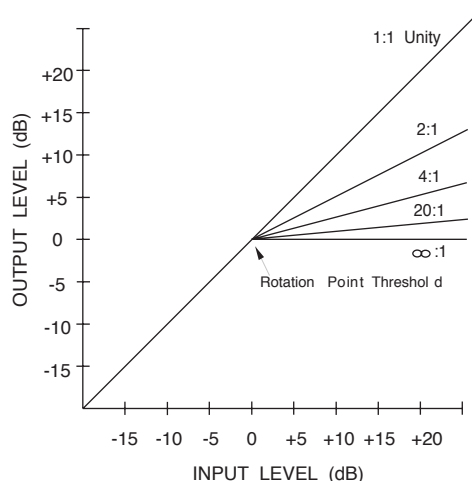

Graph 1 Threshold effect

During device operation, the audio signal limiting level is shown by the *Limiting* (point 2 on Figure 2) LED display on the front panel.

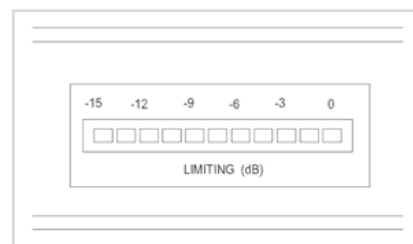

Figure 7. Limiting display



## • Process Switch

The AMCL2 features a PROCESS switch (4 on Fig. 2) which allows it to be excluded from the reproduction chain. When in OFF position, input and output connectors can be wired directly through high quality audio relay. The switch is normally used to compare the unprocessed signal with the signal resulting from using the limiter.

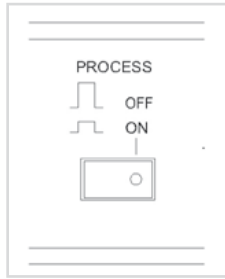

Figure 8. Process switch

## • Automatic LMAX and LEQ Control (with OPTIONAL DPC215 board)

Automatic control of action parameters is activated by setting the jumper connector (point 9 in Fig. 3) to NORMAL. The input line signal will now drive limiter action.

The default values of *Lmax* and *Leq* parameters, factory pre-set to 104.5 dB and 95 dB respectively, can be changed using the dipswitch control panel (10 in Fig. 3) situated on the rear panel next to the JUMPER CAL connector. Use dipswitches 1-6 to change the Lmax value (Fig. 9): setting the selector to ON will increase Lmax value as shown in the table below.

The Leq value can be changed using dipswitches 7-10: each dipswitch set to ON decreases LEQ value as shown in the table below.

| SETTING Lmax        |      |      |      |      |       | SETTING Leq               |      |      |      |
|---------------------|------|------|------|------|-------|---------------------------|------|------|------|
| All switch off=90dB |      |      |      |      |       | All switch off= Lmax -2dB |      |      |      |
| 1                   | 2    | 3    | 4    | 5    | 6     | 7                         | 8    | 9    | 10   |
| ON                  | ON   | ON   | ON   | ON   | ON    | ON                        | ON   | ON   | ON   |
| +0.5dB              | +1dB | +2dB | +4dB | +8dB | +16dB | -0.5dB                    | -1dB | -2dB | -4dB |

Figure 9. Dipswitch control panel

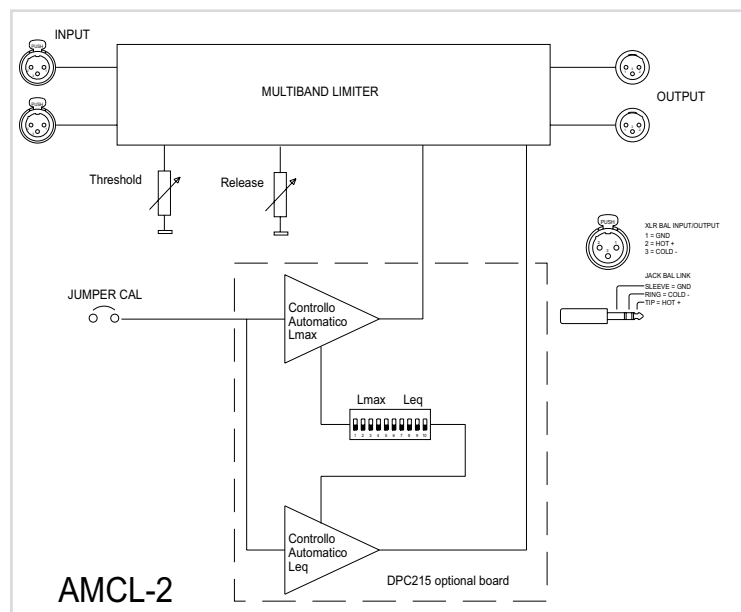

Figure 10. DPC215 board (OPTIONAL)

## 8. SETUP

Once you have connected the AMCL2 to the power mains and the input and output connectors, set the controls as follows:

1. Position the PROCESS button to ON.
2. Position the RANGE button to 0dB.
3. Position the COARSE switch to maximum value (+2dBm).
4. Position the release time to a value suitable for the function you require (see paragraph on "Release time").
5. With the JUMPER CAL off, play a piece of low density music to produce the lowest possible LEQ value.
6. Adjust the THRESHOLD value to obtain the required LEQ value. Adjust the input attenuator until the display shows attenuation varying roughly from 3dB to 6dB.
7. Should you wish to change the factory pre-set LMAX and LEQ values (LMAX = 104.5dB; LEQ = 95dB) use the dipswitch panel to set your required values.
8. Set JUMPER CAL to NORMAL.
9. Play a piece of high density music (to produce the highest possible LEQ value).
10. Perform a monitoring exercise lasting no less than 30 minutes playing different types of music genres. Record the resulting LMAX and LEQ data.
11. If the recorded values exceed allowed levels, use the various THRESHOLD, LMAX and LEQ controls to get as close as possible to the required limits.

Note: points 5, 7, and 8, are only applicable if the OPTIONAL DPC215 board is installed.

### 8.1 XLR connections

The following diagrams show the possible balanced and unbalanced connections with Cannon XLR connectors.

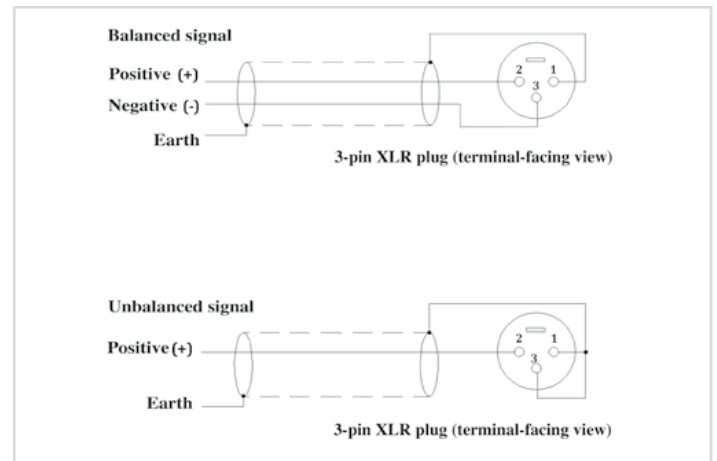
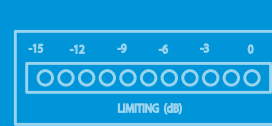
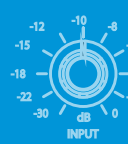

Figure 11. XLR connections





## 9. SAMPLE CONFIGURATION

A possible Peecker Sound AMCL2 application is downstream from a pre-amplifier input and upstream from an amplifier (such as the Peecker Sound PSDSP amps, mod. PS2000-PS2600-PS3400, for example).

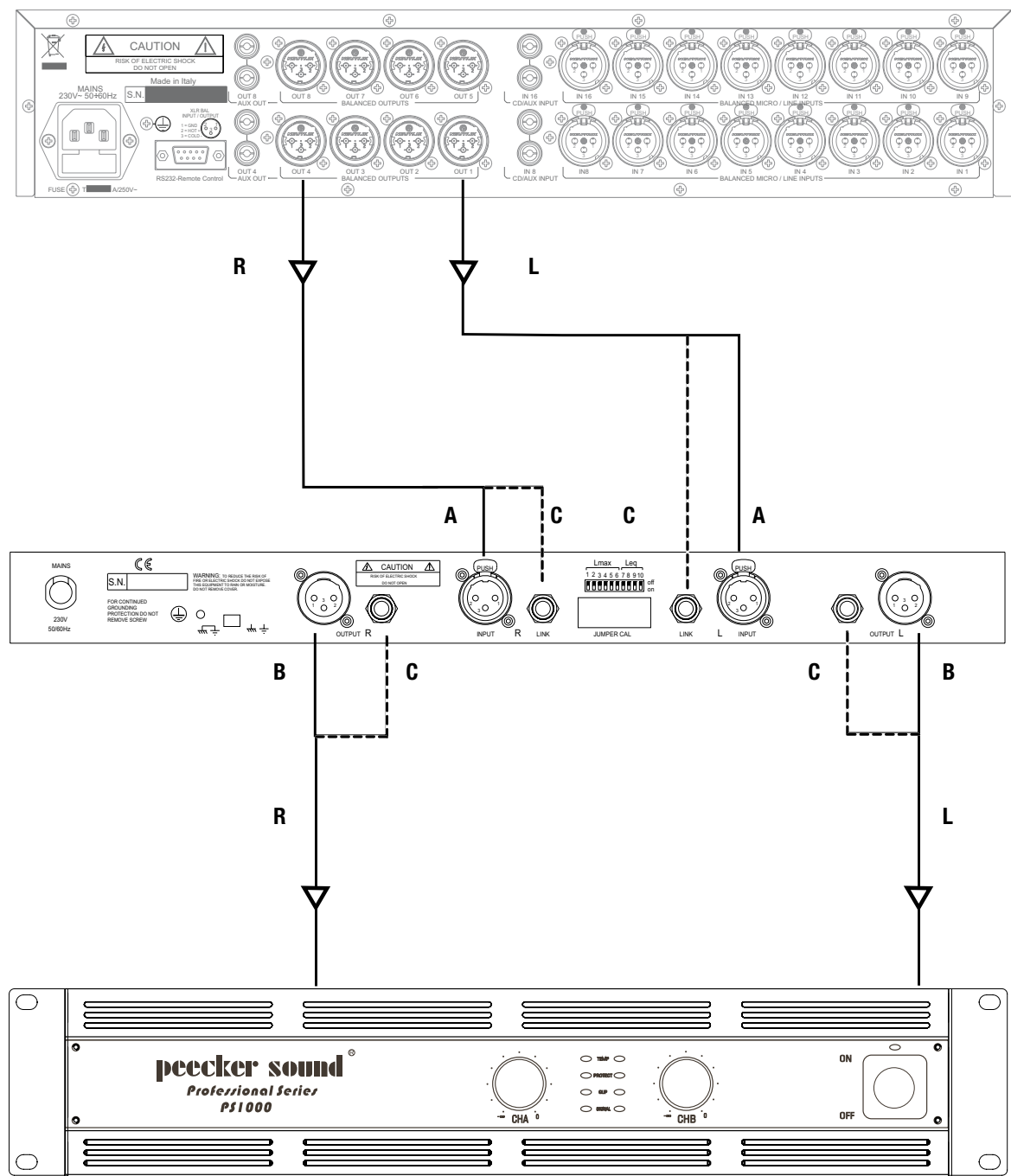
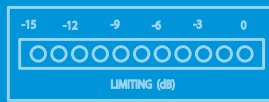
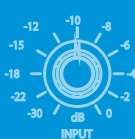

Figure 12. Sample configuration with AMCL2 between a pre-amplifier and PS1000 power amplifier



## 10. TECHNICAL SPECIFICATIONS

|                      |  |
|----------------------|--|
| Input Channels       | 2  |
| Input Impedance      | 20 kΩ, electronically balanced<br>10 kΩ, electronically unbalanced |
| Max Input Level      | +24 dBu  |
| Nominal Input Level  | 0 dBu  |
| Output Channels      | 2  |
| Output Impedance     | 140 Ω, electronically balanced<br>70 Ω, electronically unbalanced  |
| Max Output Level     | +22 dBu  |
| Nominal Output Level | 0 dBu  |

### Acoustic specifications

|                    |   |
|--------------------|---|
| Frequency Response | 16 Hz ÷ 100 kHz (+0/-3 dB)  |
| THD                | 0.005% typ (20 Hz ÷ 20 kHz)   |
| IMD -SMTPE         | 0.006%  |
| SNR                | > 90 dB with range 0 dB typ (20 Hz ÷ 20 kHz)<br>> 106 dB with range -20 dB typ (20 Hz ÷ 20 kHz) |
| Crosstalk          | - 86 dB (@ 10 kHz)  |
| CMRR               | > 66 dB   |

### Processing

|                   |   |
|-------------------|---|
| Gain              | 0 dB  |
| Time Release      | from 150 ms to 7 s                            |
| Threshold Range   | from -41 dBm to +3 dBm                        |
| Automatic Control | Lmax: 90 ÷ 121.5 dBA<br>Leq: 82,5 ÷ 119.5 dBA |

### Connectors

|               |                        |
|---------------|------------------------|
| Audio Inputs  | 3 pin female XLR, JACK |
| Audio Outputs | 3 pin male XLR, JACK   |
| Mains         | CEE 7/7 Schuko         |

### Power

|                   |                          |
|-------------------|--------------------------|
| Operating Voltage | 230 VAC ± 10% (50/60 Hz) |
| Consumption       | < 25 Watt                |

### Dimensions and Weight

|            |                     |
|------------|---------------------|
| Width      | 483 mm (19")        |
| Height     | 44 mm (1 rack unit) |
| Depth      | 285 mm              |
| Net Weight | 4.5 kg              |